

THIS DRAWING IS UNPUBLISHED. RELEASED FOR PUBLICATION ,19 .
 © COPYRIGHT 19 BY AMP INCORPORATED. ALL RIGHTS RESERVED.

LOC		DIST		REVISIONS			
P	LTR	DESCRIPTION		DATE	DWN	APVD	
	H	REV PER 0G3A-0176-02		08APR02	JR	TM	

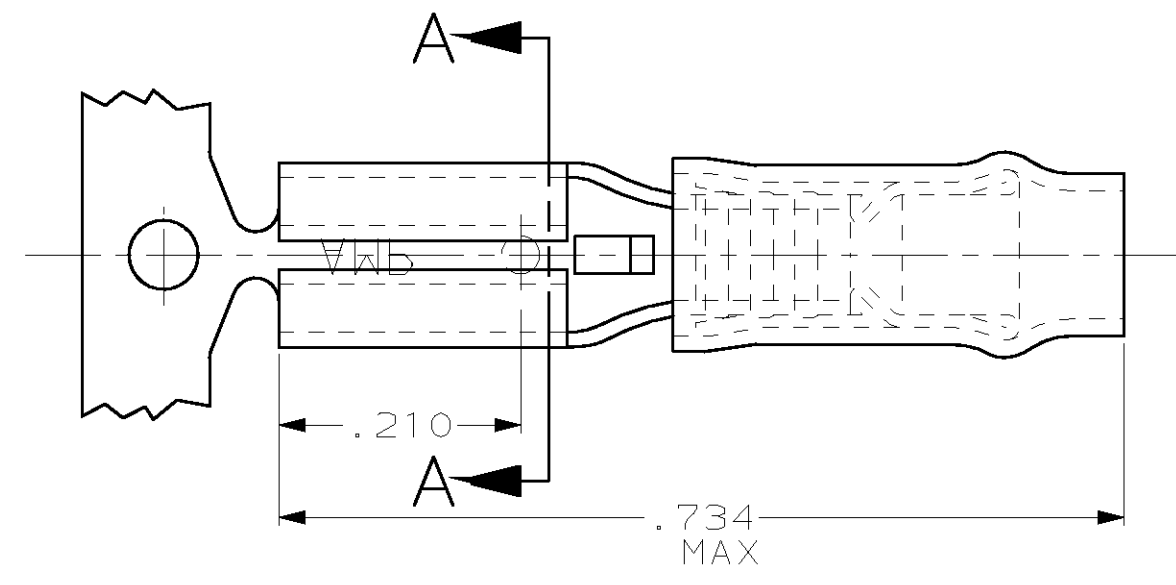

- ① 61059-2 IS REVERSED REELED OF 61059-1
- 2. THIS TERMINAL TO BE SUPPLIED CONTINUOUS STRIP, ON REELS
- 3. INSULATION RANGE .100 MAX
- 4. TAB THK .020±.001

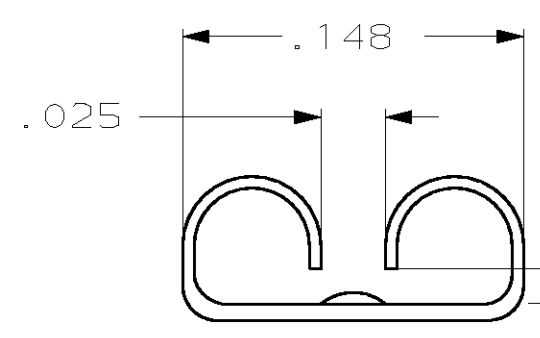

FITS "110" SERIES FASTON TAB
 (REFER TO CP-16000 FOR TAB DETAILS)

-	-	① 61059-2
QTY	PACKAGE TYPE	PART NO

AMP INCORPORATED CUSTOMER SERVICE SYSTEM	
FOR ADDITIONAL PRODUCT INFORMATION OR COPIES OF DRAWINGS AND TECHNICAL DOCUMENTS	PRODUCT INFORMATION CENTER 1-800-522-6752
FOR APPLICATION TOOLING INFORMATION	TOOLING ASSISTANCE CENTER 1-800-722-1111
FOR ORDER ENTRY	1-800-526-5142

MAX RECOMMENDED OPERATING TEMPERATURE: -
VOLTAGE RATING: -
CIRCULAR MIL AREA: -

THIS DRAWING IS A CONTROLLED DOCUMENT FOR AMP INCORPORATED. IT IS SUBJECT TO CHANGE AND THE CONTROLLING ENGINEERING ORGANIZATION SHOULD BE CONTACTED FOR THE LATEST REVISION.	
DIMENSIONS: INCHES	TOLERANCES UNLESS OTHERWISE SPECIFIED:
	0 PLC ±-
	1 PLC ±-
	2 PLC ±.015
	3 PLC ±-
	4 PLC ANGLES ±-
MATERIAL BODY, BRASS .012	FINISH BODY, PRE-TIN

DWN	13NOV95
L OLMEDA	
CHK	15NOV95
M ELLIS	
APVD	15NOV95
B BARE	
PRODUCT SPEC	
-	
APPLICATION SPEC	
-	
WEIGHT	-

AMP Incorporated Harrisburg, PA 17105-3608		
NAME RECEPTACLE, 110 SERIES, FASTON™, PIDG™, WIRE SIZE, 22-18 AWG		
SIZE	CAGE CODE	DRAWING NO
A3	00779	C-61059
CUSTOMER DRAWING		SCALE NTS
SHEET 1 OF 1		REV H